

Product name	Description	Version
MC-1612-Vxx	Dual-frequency multi-constellation GNSS positioning module	1.1

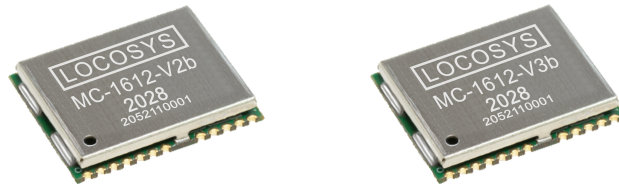

1 Introduction

LOCOSYS MC-1612-Vxx series are high-performance dual-band GNSS positioning modules that are capable of tracking all global civil navigation systems. They adopt 12 nm process and integrate efficient power management architecture to perform low power and high sensitivity. Besides, concurrent reception of L1 and L5 band signals mitigates the multipath delay and achieves sub-meter position accuracy.

The modules support hybrid ephemeris prediction to achieve faster cold start. One is self-generated ephemeris prediction (called EASY) that is no need of both network assistance and host CPU's intervention. This is valid for up to 3 days and updates automatically from time to time when GNSS module is powered on and satellites are available. The other is server-generated ephemeris prediction (called EPO) that gets from an internet server. This is valid for up to 14 days. Both ephemeris predictions are stored in the on-board flash memory and perform a cold start time less than 15 seconds.

The RF front end of MC-1612-V3b is specifically designed to comply with sensitivity specification contained in AIS 140 standard (please refer to note in the Fig 3-2). It is the best solution to those customers that design tracking applications in compliance with AIS 140.

2 Features

- Support GPS, GLONASS, GALILEO, BEIDOU, QZSS and NAVIC
- Capable of SBAS (WAAS, EGNOS, MSAS, GAGAN) and QZSS SLAS
- Support 135-channel GNSS
- Ultra low power consumption (option)
- Fast TTFF at low signal level
- Free hybrid ephemeris prediction to achieve faster cold start
- Up to 10 Hz update rate
- ± 15 ns high accuracy time pulse (PPS)
- Support Linux and Android OS driver
- Protocol support binary output
- IATF 16949 quality control
- Small form factor 16 x 12.2 x 2.4 mm
- SMD type with stamp holes; RoHS compliant

3 Application

- Personal positioning and navigation
- Automotive navigation
- Marine navigation
- Femtocell 、 Small-cell timing device

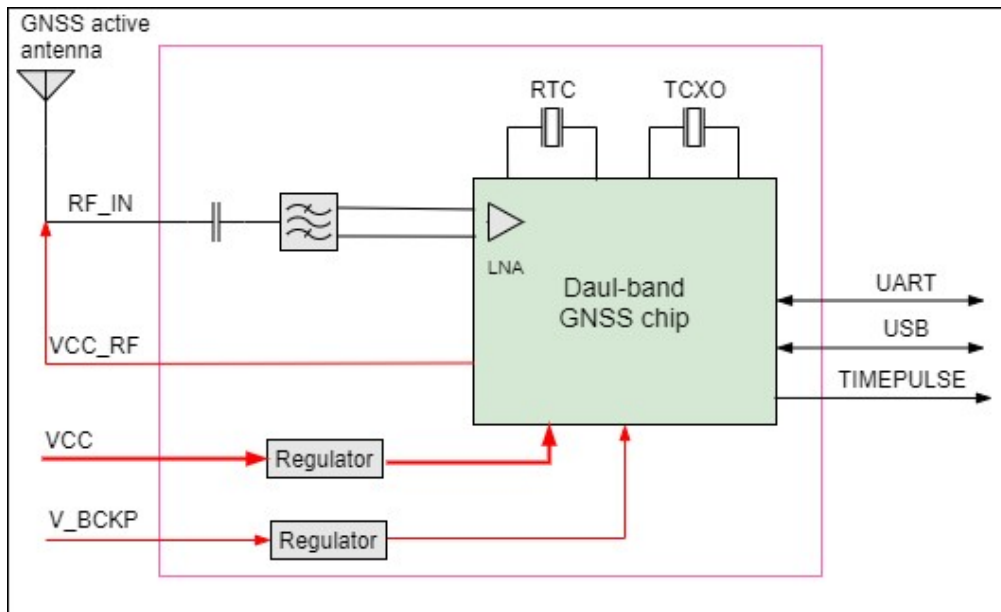

Fig 3-1 System block diagram.

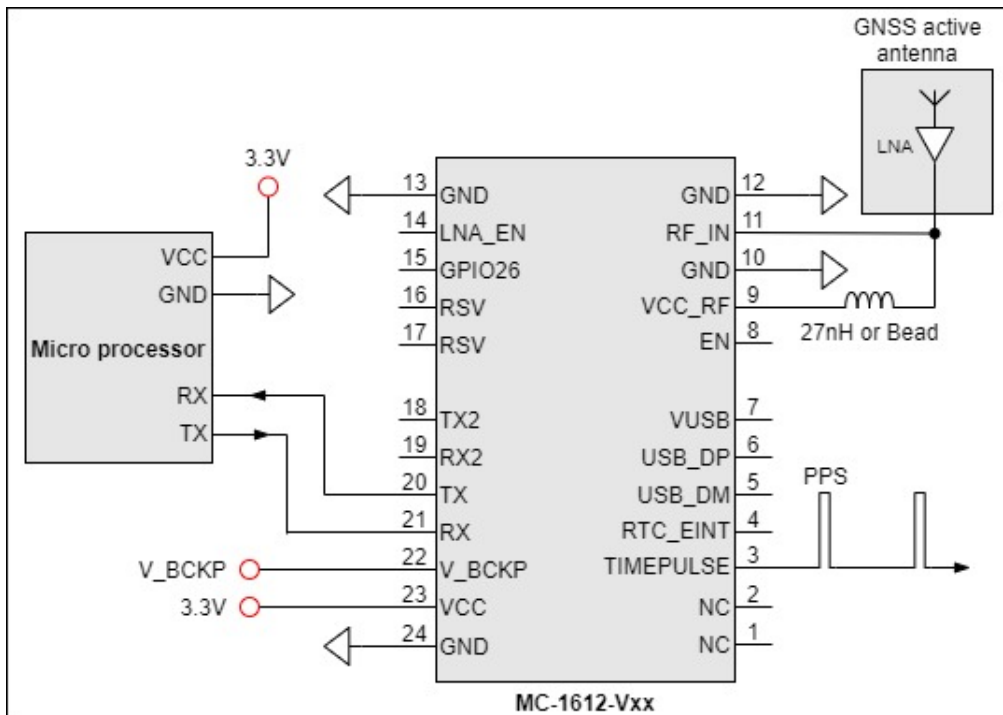

Fig 3-2 Typical application circuit that uses an active antenna.

Note: MC-1612-V3b with the active antenna can comply with the sensitivity specification contained in AIS 140 standard.

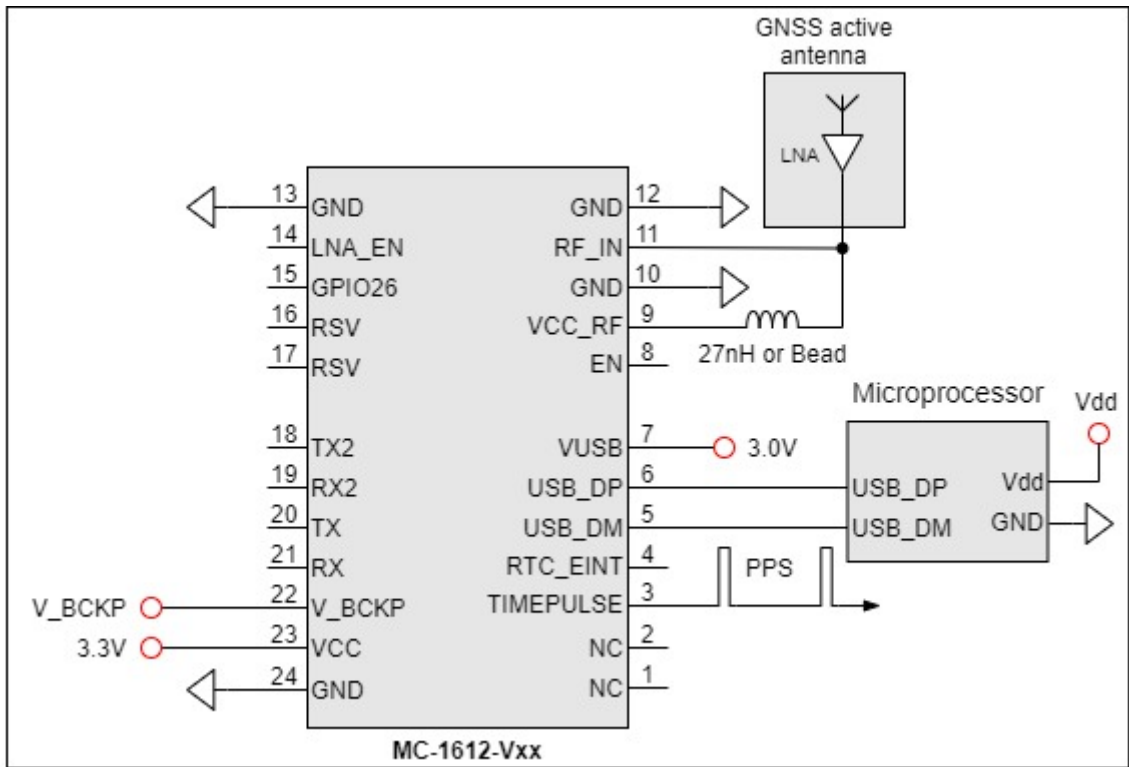

Fig 3-3 Typical application circuit that uses USB interface.

4 GNSS receiver

Frequency	MC-1612-V2b	GPS/QZSS: L1 C/A, L5C GLONASS: L1OF GALILEO: E1, E5a BEIDOU: B1I, B2a
	MC-1612-V3b	GPS/QZSS: L1 C/A GLONASS: L1OF GALILEO: E1 BEIDOU: B1I IRNSS (NAVIC): L5
Channels	Support 135 channels	
Update rate	1Hz default, up to 10Hz	
Sensitivity	Tracking	-165dBm (with external LNA)
	Cold start	-148dBm (with external LNA)
Acquisition Time	Hot start (Open Sky)	1s (typical)
	Cold Start (Open Sky)	28s (typical) without AGPS
		< 15s (typical) with AGPS (ephemeris prediction)
Position Accuracy	MC-1612-V2b	Autonomous: 1.5m (CEP) ⁽¹⁾
	MC-1612-V3b	Autonomous: 2.5m (CEP)
Max. Altitude	< 18,000 m	
Max. Velocity	< 500m/s	
Protocol Support ⁽²⁾	NMEA 0183 ver. 4.1	115200 bps ⁽³⁾ , 8 data bits, no parity, 1 stop bits (default) 1Hz: GGA, GLL, GSA, GSV, RMC, VTG, GST

Note 1: Open sky, dual band, demonstrated with a good external LNA.

Note 2: The module protocol support binary output, if customers want to the product to support it, please contact us in advance.

Note 3: Both baud rate and output message rate are configurable to be factory default.

5 Software interface

5.1 NMEA output message

Table 5.1-1 NMEA output message

NMEA record	Description
GGA	Global positioning system fixed data
GLL	Geographic position - latitude/longitude
GSA	GNSS DOP and active satellites
GSV	GNSS satellites in view
RMC	Recommended minimum specific GNSS data
VTG	Course over ground and ground speed
GST	Estimated error in position solution

● GGA--- Global Positioning System Fixed Data

Table 5.1-2 contains the values for the following example:

```
$GNGGA,091250.000,2503.71250,N,12138.74514,E,1,32,0.55,119.0,M,17.2,M,,*7E
```

Table 5.1-2 GGA Data Format

Name	Example	Units	Description
Message ID	\$GNGGA		GGA protocol header
UTC Time	091250.000		hhmmss.sss
Latitude	2503.71250		ddmm.mmmmm
N/S indicator	N		N=north or S=south
Longitude	12138.74514		dddmm.mmmmm
E/W Indicator	E		E=east or W=west
Position Fix Indicator	1		See Table 5.1-3
Satellites Used	32		Number of satellites in view
HDOP	0.55		Horizontal Dilution of Precision (meters)
MSL Altitude	119.0	meters	Antenna Altitude above/below mean-sea-level (geoid) (in meters)
Units	M	meters	Units of antenna altitude, meters
Geoidal Separation	17.2	meters	
Units	M	meters	Units of geoidal separation, meters
Age of diff. GNSS data		second	Null fields when DGPS is not used
Diff. Ref. Station ID			Differential reference station ID, 0000-1023
Checksum	*7E		Checksum
<CR> <LF>			End of message termination

Table 5.1-3 Position Fix Indicators

Value	Description
-------	-------------

0	No position fix
1	Autonomous GNSS fix
2	Differential GNSS fix
4	RTK fixed
5	RTK float

● **GLL--- Geographic Position – Latitude/Longitude**

Table 5.1-4 contains the values for the following example:

\$GNGLL,2503.71193,N,12138.74582,E,094450.000,A,A*47

Table 5.1-4 GLL Data Format

Name	Example	Units	Description
Message ID	\$GNGLL		GLL protocol header
Latitude	2503.71193		ddmm.mmmmm
N/S indicator	N		N=north or S=south
Longitude	12138.74582		dddmm.mmmmm
E/W indicator	E		E=east or W=west
UTC Time	094450.000		hhmmss.sss
Status	A		A=data valid or V=data not valid
Mode	A		N = No position fix A = Autonomous GNSS fix D = Differential GNSS fix R = RTK fixed F = RTK float E = Estimated/Dead reckoning fix
Checksum	*47		
<CR> <LF>			End of message termination

● **GSA---GNSS DOP and Active Satellites**

Table 5.1-5 contains the values for the following example:

\$GNGSA,A,3,11,195,194,199,08,07,01,27,16,09,23,,1.19,0.64,1.00,1*3F

\$GNGSA,A,3,87,81,76,,,,,,,,,1.19,0.64,1.00,2*0F

\$GNGSA,A,3,,,,,,,,,,,,,1.19,0.64,1.00,3*09

\$GNGSA,A,3,34,24,12,07,11,10,08,38,25,09,13,16,1.19,0.64,1.00,4*02

Table 5.1-5 GSA Data Format

Name	Example	Units	Description
Message ID	\$GNGSA		GSA protocol header
Mode 1	A		See Table 5.1-6

Mode 2	3		See Table 5.1-7
ID of satellite used	11		SV on Channel 1
ID of satellite used	195		SV on Channel 2
....		
ID of satellite used			SV on Channel 12
PDOP	1.19		Position Dilution of Precision
HDOP	0.64		Horizontal Dilution of Precision
VDOP	1.00		Vertical Dilution of Precision
GNSS system ID	1		See Table 5.1-8
Checksum	*3F		
<CR> <LF>			End of message termination

Table 5.1-6 Mode 1

Value	Description
M	Manually set to operate in 2D or 3D mode
A	Automatically switching between 2D or 3D mode

Table 5.1-7 Mode 2

Value	Description
1	No position fix
2	2D fix
3	3D fix

Table 5.1-8 GNSS system ID

Value	Description
1	GPS
2	GLONASS
3	GALILEO
4	BEIDOU
6	IRNSS

● GSV---GNSS Satellites in View

Table 5.1-9 contains the values for the following example:

\$GPGSV,3,1,09,8,71,268,47,27,63,18,49,11,44,191,46,4,41,237,46,1*54

\$GPGSV,3,2,09,16,38,42,42,9,32,279,39,26,22,70,38,31,15,131,36,1*56

\$GPGSV,3,3,09,7,15,320,40,1*6B

\$GPGSV,1,1,04,8,71,268,50,27,63,18,49,9,32,279,43,26,22,70,42,8*6C

\$GLGSV,2,1,05,82,63,47,47,83,56,182,36,80,47,9,42,79,33,85,45,1*71

\$GLGSV,2,2,05,81,15,27,37,1*71

\$GAGSV,1,1,04,08,48,300,43,03,47,025,45,13,36,309,42,05,06,061,34,7*79

\$GAGSV,1,1,04,08,48,300,43,03,47,025,47,13,36,309,43,05,06,061,33,1*7B
 \$GBGSV,5,1,17,12,80,182,47,24,64,5,51,7,58,355,44,3,57,205,45,1*7C
 \$GBGSV,5,2,17,1,54,141,44,34,52,211,49,9,48,230,45,10,47,316,42,1*79
 \$GBGSV,5,3,17,26,44,100,47,16,39,207,43,4,38,117,41,2,37,240,41,1*77
 \$GBGSV,5,4,17,39,37,210,43,6,36,198,41,38,27,173,41,25,18,317,42,1*4E
 \$GBGSV,5,5,17,35,16,39,40,1*7F
 \$GBGSV,1,1,02,24,64,5,50,26,44,100,43,4*77

Table 5.1-9 GSV Data Format

Name	Example	Units	Description
Message ID	\$GPGSV		GSV protocol header GP=GPS/QZSS, GL=GLONSS, GA=GALILEO, GB=BEIDOU, GI=IRNSS.
Total number of messages	3		Range 1 to 9
Message number	1		Range 1 to 9
Satellites in view	09		
Satellite ID	8		Channel 1
Elevation	71	degrees	Channel 1 (Range 00 to 90)
Azimuth	268	degrees	Channel 1 (Range 000 to 359)
SNR (C/No)	47	dB-Hz	Channel 1 (Range 00 to 99, null when not tracking)
....		
Satellite ID	4		Channel 4 (Range 01 to 196)
Elevation	41	degrees	Channel 4 (Range 00 to 90)
Azimuth	237	degrees	Channel 4 (Range 000 to 359)
SNR (C/No)	46	dB-Hz	Channel 4 (Range 00 to 99, null when not tracking)
Signal ID	1		GPS/QZSS: L1 C/A=1, L5Q=8 GLONASS: L1 C/A=1 GALILEO: E1=7, E5a=1 BEIDOU: B1=1, B2a=4 IRNSS: L6=1
Checksum	*54		
<CR> <LF>			End of message termination

● **RMC---Recommended Minimum Specific GNSS Data**

Table 5.1-10 contains the values for the following example:

\$GNRMC,070143.000,A,2503.71317,N,12138.74533,E,0.002,70.50,130220,,,A,V*01

Table 5.1-10 RMC Data Format

Name	Example	Units	Description
------	---------	-------	-------------

Message ID	\$GNRMC		RMC protocol header
UTC Time	070143.000		hhmmss.sss
Status	A		A=data valid or V=data not valid
Latitude	2503.71317		ddmm.mmmmm
N/S Indicator	N		N=north or S=south
Longitude	12138.74533		dddmm.mmmmm
E/W Indicator	E		E=east or W=west
Speed over ground	0.002	knots	True
Course over ground	70.50	degrees	
Date	130220		ddmmyy
Magnetic variation		degrees	
Variation sense			E=east or W=west
Mode	A		N = No position fix A = Autonomous GNSS fix D = Differential GNSS fix R = RTK fixed F = RTK float E = Estimated/Dead reckoning fix
Navigational status indicator	V		S = Safe C = Caution U = Unsafe V = Void
Checksum	*01		
<CR> <LF>			End of message termination

● VTG---Course Over Ground and Ground Speed

Table 5.1-11 contains the values for the following example:

\$GNVTG,0.00,T,,M,0.003,N,0.006,K,A*26

Table 5.1-11 VTG Data Format

Name	Example	Units	Description
Message ID	\$GNVTG		VTG protocol header
Course over ground	0.00	degrees	Measured heading
Reference	T		True
Course over ground		degrees	Measured heading
Reference	M		Magnetic
Speed over ground	0.003	knots	Measured speed
Units	N		Knots

Speed over ground	0.006	km/hr	Measured speed
Units	K		Kilometer per hour
Mode	A		N = No position fix A = Autonomous GNSS fix D = Differential GNSS fix R = RTK fixed F = RTK float E = Estimated/Dead reckoning fix
Checksum	*26		
<CR> <LF>			End of message termination

● **GST---Estimated error in position solution**

Table 5.1-12 contains the values for the following example:

\$GNGST,075707.000,2.9,1.8,1.5,113.3,1.6,1.8,5.9*7F

Table 5.1-12 GST Data Format

Name	Example	Units	Description
Message ID	\$GNGST		GST protocol header
UTC Time	075707.000		hhmmss.sss
RangeRMS	2.9	meters	RMS value of the standard deviation of the ranges
stdMajor	1.8	meters	Standard deviation of semi-major axis of error ellipse
stdMinor	1.5	meters	Standard deviation of semi-minor axis of error ellipse
Orient	113.3	degrees	Orientation of semi-major axis of error ellipse
stdLat	1.6	meters	Standard deviation of latitude error
stdLong	1.8	meters	Standard deviation of longitude error
stdAlt	5.9	meters	Standard deviation of altitude error
Checksum	*7F		
<CR> <LF>			End of message termination

5.2 Proprietary commands

The commonly used commands are in the following.

5.2.1 ID: 001

[Description]

PAIR_ACK. Acknowledge of the input command.

[Return]

\$PAIR001,Command_ID,Result*CS<CR><LF>

Command ID: The command / packet type the acknowledge responds.

Result: The result of the command.

0: The command was successfully sent.

1: The command is processing. You must wait for the result.

2: Sending the command failed.

3: This command ID is not supported.

4: Command parameter error. Out of range / some parameters were lost / checksum error.

5: Service is busy. You can try again soon.

[Example]

Send:

\$PAIR002*38\r\n

Response:

\$PAIR001,002,0*39\r\n ==> Success

5.2.2 ID: 002

[Description]

Power on the GNSS system. Include DSP/RF/Clock and other GNSS sections.

[Data Field]

\$PAIR002*CS<CR><LF>

[Return]

PAIR_ACK for send result.

[Example]

Send:

\$PAIR002*38\r\n

Response:

\$PAIR001,002,1*38\r\n ==> The power on process is running. Please wait a moment.

\$PAIR001,002,0*39\r\n ==> Power on was successful.

5.2.3 ID: 003

[Description]

Power off GNSS system. Include DSP/RF/Clock and other GNSS sections. The location service is not available after this command is executed. The module can still receive configuration commands.

[Data Field]

```
$PAIR003*CS<CR><LF>
```

[Return]

PAIR_ACK for send result.

[Example]

Send:

```
$PAIR003*39\r\n
```

Response:

```
$PAIR001,003,1*39\r\n ==> The power off process is running. Please wait a moment.
```

```
$PAIR001,003,0*38\r\n ==> Power off was successful.
```

5.2.4 ID: 004

[Description]

Hot Start. Use the available data in the NVRAM.

[Data Field]

```
$PAIR004*CS<CR><LF>
```

[Return]

PAIR_ACK for send result.

[Example]

Send:

```
$PAIR004*3E\r\n
```

Response:

```
$PAIR001,004,0*3F\r\n ==> Success
```

5.2.5 ID: 005

[Description]

Warm Start. Not using Ephemeris data at the start.

[Data Field]

```
$PAIR005*CS<CR><LF>
```

[Return]

PAIR_ACK for send result.

[Example]

Send:

```
$PAIR005*3F\r\n
```

Response:

\$PAIR001,005,0*3E\r\n ==> Success

5.2.6 ID: 006

[Description]

Cold Start. Not using the Position, Almanac and Ephemeris data at the start.

[Data Field]

\$PAIR006*CS<CR><LF>

[Return]

PAIR_ACK for send result.

[Example]

Send:

\$PAIR006*3C\r\n

Response:

\$PAIR001,006,0*3D\r\n ==> Success

5.2.7 ID: 007

[Description]

Full Cold Start.

In addition to Cold start, this command clears the system/user configurations at the start.

It resets the GNSS module to the factory default.

[Data Field]

\$PAIR007*CS<CR><LF>

[Return]

PAIR_ACK for send result.

[Example]

Send:

\$PAIR007*3D\r\n

Response:

\$PAIR001,007,0*3C\r\n ==> Success

5.2.8 ID: 864

[Description]

Set baud rate configuration.

[Data Field]

\$PAIR864,<Port_Type>,<Port_Index>,<Baudrate>*CS<CR><LF>

Port_Type: HW Port Type.

0: UART

Port_Index: HW Port Index

0: UART0

Baudrate: the baud rate needs config.

Support 115200, 230400, 460800, 921600, 3000000

[Return]

PAIR_ACK for send result.

[Example]

Send:

```
$PAIR864,0,0,115200*1B\r\n
```

Response:

```
$PAIR001,864,0*31\r\n ==> Success
```

[Note]

The change will take effect after reboot.

5.2.9 ID: 050

[Description]

Set Position Fix Interval.

If set less than 1000 ms, ASCII NMEA will automatically increase the update interval in order to decrease IO throughput.

[Data Field]

```
$PAIR050,<Fix_Interval>*CS<CR><LF>
```

Fix_Interval: Position fix interval in milliseconds (ms). [Range: 100 ~ 1000]

[Return]

PAIR_ACK for send result.

[Example]

Send:

```
$PAIR050,1000*12\r\n
```

Response:

```
$PAIR001,050,0*3E\r\n ==> Success
```

5.2.10 ID: 051

[Description]

Get Position Fix Interval.

[Data Field]

```
$PAIR051*CS<CR><LF>
```

[Return]

1. PAIR_ACK for send result.

2. \$PAIR050,<Fix_Interval>*CS<CR><LF>

Fix_Interval: Position fix interval in milliseconds (ms). [Range: 100 ~ 1000]

[Example]

Send:

```
$PAIR051*3E\r\n
```

Response:

```
$PAIR001,051,0*3F\r\n ==> Success
```

```
$PAIR051,1000*13\r\n
```

5.2.11 ID: 062

[Description]

Set the NMEA sentence output interval of corresponding NMEA type.

[Data Field]

```
$PAIR062,<Type>,<Output_Rate>*CS<CR><LF>
```

Type: NMEA Type

-1 Reset all sentence to default value.

0 NMEA_SEN_GGA, // GGA interval - GPS Fix Data

1 NMEA_SEN_GLL, // GLL interval - Geographic Position - Latitude longitude

2 NMEA_SEN_GSA, // GSA interval - GNSS DOPS and Active Satellites

3 NMEA_SEN_GSV, // GSV interval - GNSS Satellites in View

4 NMEA_SEN_RMC, // RMC interval - Recommended Minimum Specific GNSS Sentence

5 NMEA_SEN_VTG, // VTG interval - Course Over Ground and Ground Speed

6 NMEA_SEN_ZDA, // ZDA interval - Time & Date

7 NMEA_SEN_GRS, // GRS interval - GNSS Range Residuals

8 NMEA_SEN_GST, // GST Interval - GNSS Pseudorange Error Statistics

Output_Rate: Output interval setting (Valid range: 0~20)

0 - Disabled or not supported sentence

1 - Output once every one position fix

2 - Output once every two position fixes

3 - Output once every three position fixes

4 - Output once every four position fixes

5 - Output once every five position fixes

[Return]

PAIR_ACK for send result.

[Example]

Send:

```
$PAIR062,0,3*3D\r\n
```

Response:

```
$PAIR001,062,0*3F\r\n ==> Success
```

5.2.12 ID: 063

[Description]

Get the NMEA sentence output interval of corresponding NMEA type.

[Data Field]

\$PAIR063,<Type>*CS<CR><LF>

Type: NMEA Type

-1 return all sentence configuration.

0 NMEA_SEN_GGA,	// GGA interval - GPS Fix Data
1 NMEA_SEN_GLL,	// GLL interval - Geographic Position - Latitude longitude
2 NMEA_SEN_GSA,	// GSA interval - GNSS DOPS and Active Satellites
3 NMEA_SEN_GSV,	// GSV interval - GNSS Satellites in View
4 NMEA_SEN_RMC,	// RMC interval - Recommended Minimum Specific GNSS Sentence
5 NMEA_SEN_VTG,	// VTG interval - Course Over Ground and Ground Speed
6 NMEA_SEN_ZDA,	// ZDA interval - Time & Date
7 NMEA_SEN_GRS,	// GRS interval - GNSS Range Residuals
8 NMEA_SEN_GST,	// GST Interval - GNSS Pseudorange Error Statistics

[Return]

1. PAIR_ACK for send result.

2. \$PAIR063,<Type>,<Output_Rate>*CS<CR><LF>

Type: NMEA Type

0 NMEA_SEN_GGA,	// GGA interval - GPS Fix Data
1 NMEA_SEN_GLL,	// GLL interval - Geographic Position - Latitude longitude
2 NMEA_SEN_GSA,	// GSA interval - GNSS DOPS and Active Satellites
3 NMEA_SEN_GSV,	// GSV interval - GNSS Satellites in View
4 NMEA_SEN_RMC,	// RMC interval - Recommended Minimum Specific GNSS Sentence
5 NMEA_SEN_VTG,	// VTG interval - Course Over Ground and Ground Speed
6 NMEA_SEN_ZDA,	// ZDA interval - Time & Date
7 NMEA_SEN_GRS,	// GRS interval - GNSS Range Residuals
8 NMEA_SEN_GST,	// GST Interval - GNSS Pseudorange Error Statistics

Output_Rate: Output interval setting (Valid range: 0~20, default value: 1)

- 0 - Disabled or not supported sentence
- 1 - Output once every one position fix
- 2 - Output once every two position fixes
- 3 - Output once every three position fixes
- 4 - Output once every four position fixes
- 5 - Output once every five position fixes

[Example]

Send:

\$PAIR063,0*23\r\n

Response:

\$PAIR001,063,0*3E\r\n ==> Success

\$PAIR063,0,3*3C\r\n

5.2.13 ID: 071

[Description]

Query the static navigation speed threshold.

[Data Field]

\$PAIR071*CS<CR><LF>

[Return]

1. PAIR_ACK for send result.
2. \$PAIR071,<Speed_threshold>*CS<CR><LF>

Speed_threshold: 0~2 m/s.

The maximum is 2.0 m/s.

[Example]

Send:

\$PAIR071*3C\r\n

Response:

\$PAIR001,071,0*3D\r\n ==> Success

\$PAIR071,0.4*3A\r\n

5.2.14 ID: 080

[Description]

Set navigation mode.

[Data Field]

\$PAIR080,<CmdType>*CS<CR><LF>

CmdType:

0. Normal mode: For general purpose
1. Fitness mode: For running and walking purpose so that the low-speed (< 5 m/s) movement will have more of an effect on the position calculation.
2. Reserved
3. Reserved
4. Stationary mode: For stationary applications with zero dynamics.
5. Reserved
6. Reserved
7. Swimming mode: For swimming purpose so that it smooths the trajectory and improves the accuracy of distance calculation.

[Return]

PAIR_ACK for send result.

[Example]

Send:

\$PAIR080,1*2F\r\n ==> Enter fitness mode.

Response:

\$PAIR001,080,0*33\r\n ==> Success

5.2.15 ID: 081

[Description]

Get navigation mode.

[Data Field]

\$PAIR081*CS<CR><LF>

[Return]

1. PAIR_ACK for send result.
2. \$PAIR081,<CmdType>*CS<CR><LF>

CmdType:

- '0' [Default Value] Normal mode: For general purpose
- '1' Fitness mode: For running and walking activities so that the low-speed (< 5 m/s) movement will have more of an effect on the position calculation.
- '2' Reserved
- '3' Reserved
- '4' Stationary mode: For stationary applications where a zero dynamic assumed.
- '5' Reserved
- '6' Reserved
- '7' Swimming mode: For swimming purpose so that it smooths the trajectory and improves the accuracy of distance calculation.

[Example]

Send:

\$PAIR081*33\r\n

Response:

\$PAIR001,081,0*32\r\n ==> Success

\$PAIR081,1*2E\r\n ==> Current is fitness mode.

5.2.16 ID: 400

[Description]

Set DGPS correction data source mode.

[Data Field]

\$PAIR400,<Mode> *CS<CR><LF>

Mode: DGPS data source mode.

- '0': No DGPS source
- '1': RTCM
- '2': SBAS (Include WAAS/EGNOS/GAGAN/MSAS)
- '3': QZSS SLAS

[Return]

PAIR_ACK for send result.

[Example]

Send:

\$PAIR400,2*20\r\n ==> Set SBAS Mode

Response:

\$PAIR001,400,0*3F\r\n ==> Success

5.2.17 ID: 401

[Description]

Query the DGPS data source mode.

[Data Field]

\$PAIR401 *CS<CR><LF>

[Return]

1. PAIR_ACK for send result.
2. \$PAIR401,<Mode>*CS<CR><LF>

Mode: DGPS data source mode.

- '0': No DGPS source
- '1': RTCM
- '2': SBAS (Include WAAS/EGNOS/GAGAN/MSAS)
- '3': QZSS SLAS

[Example]

Send:

\$PAIR401*3F\r\n

Response:

\$PAIR001,401,0*3E\r\n ==> Success

\$PAIR401,2*21\r\n ==> SBAS Mode

5.2.18 ID: 410

[Description]

Enable searching a SBAS satellite or not.

When navigation mode is Fitness or Swimming mode, SBAS is not supported.

[Data Field]

\$PAIR410,<Enabled>*CS<CR><LF>

Enabled: Enable or disable

'0' = Disable

'1' = Enable

[Return]

PAIR_ACK for send result.

[Example]

Send:

\$PAIR410,1*22\r\n ==> Enable SBAS

Response:

\$PAIR001,410,0*3E\r\n ==> Success

5.2.19 ID: 420**[Description]**

Enable the QZSS SLAS (Sub-meter Level Augmentation Service) operation.

When navigation mode is Fitness or Swimming mode, QZSS SLAS is not supported.

[Data Field]

\$PAIR420,<Enabled>*CS<CR><LF>

Enabled: Enable or disable

'0' = Disable

'1' = Enable

[Return]

PAIR_ACK for send result.

[Example]

Send:

\$PAIR420,1*21\r\n ==> Enable QZSS SLAS

Response:

\$PAIR001,420,0*3D\r\n ==> Success

5.2.20 ID: 513**[Description]**

Save the current configuration from RTC RAM to flash.

[Data Field]

\$PAIR513*CS<CR><LF>

[Return]

PAIR_ACK for send result.

[Example]

Send:

```
$PAIR513*3D\r\n
```

Response:

```
$PAIR001,513,0*3C\r\n
```

[Note]

The changes of the configuration are kept in the RTC RAM that is powered from V_BCKP pin. If the power from V_BCKP pin is not kept, the changes will be lost after system reboot. The user can use this command to save the changes into the non-volatile flash memory.

5.2.21 ID: 514

[Description]

Clear the current configuration and restore the factory default settings. This function does not support run time restore when GNSS is power on. Please send \$PAIR003 command to power off GNSS before using this command.

[Data Field]

```
$PAIR514*CS<CR><LF>
```

[Return]

PAIR_ACK for send result.

[Example]

Send:

```
$PAIR514*3A\r\n
```

Response:

```
$PAIR001,514,0*3B\r\n
```

5.2.22 ID: 890

[Description]

This command is used to set geofencing configuration.

[Data Field]

```
$PAIR890,<FenceNum>,<ConfLvl>,<Lat1>,<Lon1>,<Rad1>,...,<RadN>*CS<CR><LF>
```

FenceNum(N): Number of geofences, the value is limited to 4.

When the value is set to 0, the geofencing function is disabled.

ConfLvl: The confidence level for state evaluation.

- '0' No requirement
- '1' 1-Sigma (68%)
- '2' 2-Sigma (95%)
- '3' 3-Sigma (99.7%)
- '4' 4-Sigma (99.99%)
- '5' 5-Sigma (99.9999%)

Lat: Latitude of the geofence circle center (deg)

Lon: Longitude of the geofence circle center (deg)

Rad: Radius of the geofence circle (m)

[Return]

PAIR_ACK for send result.

[Example]

Enable the geofencing function:

Send:

```
$PAIR890,1,1,25.0567,121.5743,30*20\r\n
```

Response:

```
$PAIR001,890,0*3A\r\n ==> Success
```

Disable the geofencing function:

Send:

```
$PAIR890,0*27\r\n
```

Response:

```
$PAIR001,890,0*3A\r\n ==> Success
```

5.2.23 ID: 891

[Description]

This command is used to get geofencing configuration.

[Data Field]

```
$PAIR891*CS<CR><LF>
```

[Return]

PAIR_ACK for send result.

```
$PAIR891,<FenceNum>,<ConfLvl>,<Lat1>,<Lon1>,<Rad1>,...,<RadN>*CS<CR><LF>
```

FenceNum(N): Number of geofences, the value is limited to 4.

ConfLvl: The confidence level for state evaluation.

'0' No requirement

'1' 1-Sigma (68%)

'2' 2-Sigma (95%)

'3' 3-Sigma (99.7%)

'4' 4-Sigma (99.99%)

'5' 5-Sigma (99.9999%)

Lat: Latitude of the geofence circle center (deg)

Lon: Longitude of the geofence circle center (deg)

Rad: Radius of the geofence circle (m)

[Example]

Send:

\$PAIR891*3A\r\n

Response:

\$PAIR001,891,0*3B\r\n ==> Success

\$PAIR891,1,1,25.0567,121.5743,30*21\r\n

5.2.24 ID: 380

[Description]

Enable/Disable DCB output (only support L1+L5 SW package)

[Data Field]

\$PAIR380,<Enable>*CS<CR><LF>

Enable:

0: Disable

1: Enable

[Return]

PAIR_ACK for send result.

[Example]

Send:

\$PAIR380,1*2C\r\n

Response:

\$PAIR001,380,0*30\r\n ==> Success

5.2.25 ID: 381

[Description]

Output current DCB value (only support L1+L5 SW package)

[Return]

\$PAIR381,<Count>,<GPS_DCB_mean>,<GPS_DCB_std>,<GAL_DCB_mean>,<GAL_DCB_std>,<BDS_DCB_mean>,<BDS_DCB_std>,<QZS_DCB_mean>,<QZS_DCB_std>*CS<CR><LF>

Count: epoch count

GPS_DCB_mean: GPS L1/L5 DCB mean during "Count" epochs

GPS_DCB_std: GPS L1/L5 DCB standard deviation during "Count" epochs

GAL_DCB_mean: GAL E1/E5a DCB mean during "Count" epochs

GAL_DCB_std: GAL E1/E5a DCB standard deviation during "Count" epochs

BDS_DCB_mean: BDS B1/B2a DCB mean during "Count" epochs

BDS_DCB_std: BDS B1/B2a DCB standard deviation during "Count" epochs

QZS_DCB_mean: QZS L1/L5 DCB mean during "Count" epochs

QZS_DCB_std: QZS L1/L5 DCB standard deviation during "Count" epochs

[Example]

Send:

\$PAIR380,1*2C\r\n

Response:

\$PAIR001,380,0*30\r\n

\$PAIR381,300,0.02,0.01,0.01,0.01,0.05,0.01,0.03,0.01*2A\r\n

5.2.26 ID: 112

[Description]

Set DCB values of satellites (GPS/QZSS/GLEO/BD)

[Data Field]

\$PAIR112,<GPS DCB_mean>,<QZSS DCB_mean >,<Galileo DCB_mean >,<Beidou
DCB_mean >*CS

[Return]

PAIR_ACK for send result

[Example]

Send:

\$PAIR112,-11.04,-11.04,-7.79,-11.04*05

Response:

\$PAIR001,112,0*39

\$PAIR113,-11.040000,-11.040000,-7.790000,-11.040000*04

5.2.27 ID: 113

[Description]

Get DCB values of satellites (GPS/QZSS/GLEO/BD)

[Data Field]

\$PAIR113,<GPS DCB_mean>,<QZSS DCB_mean >,<Galileo DCB_mean >,<Beidou
DCB_mean >*CS

[Return]

PAIR_ACK for send result

[Example]

Send:

\$PAIR113,-11.04,-11.04,-7.79,-11.04*05

Response:

\$PAIR001,113,0*38

\$PAIR113,-11.040000,-11.040000,-7.790000,-11.040000*04

5.3 Geofence

This function enables the user to assign the desired areas for the geofencing application. It can be up to 4 desired areas at the same time.

Each area is composed of a circle. Enter the latitude and longitude as the center of the circle, and the maximum radius is 65535 meters.

- When the GNSS module is in one of the circular areas, GPIO26 outputs low level.
- When the GNSS module is outside all the circular areas or on the boundary, GPIO26 outputs high level.
- When the status is unknown or the geofencing function is not enabled, GPIO26 outputs high level.

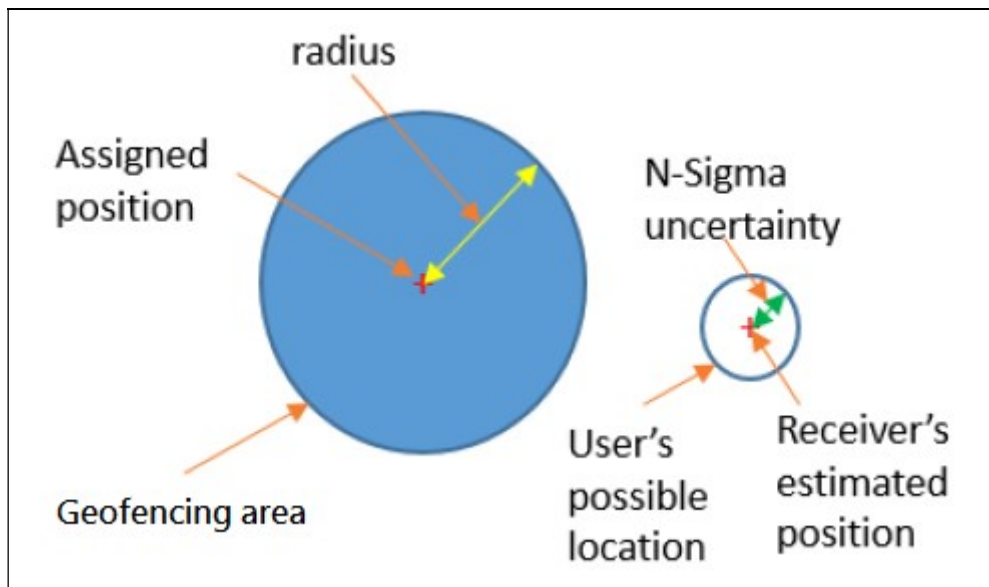

6 Pin assignment and descriptions

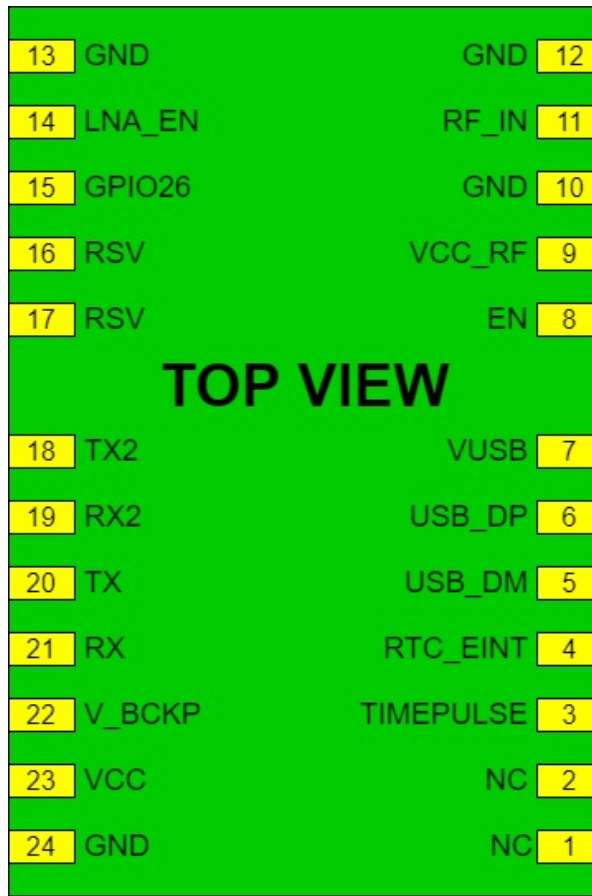

Table 6-1 Pin descriptions

Pin #	Name	Type	Description	Note
1	NC		Not connect	
2	NC		Not connect	
3	TIMEPULSE	O	Time pulse (PPS, default 100 ms pulse/sec when GNSS fix is available. Output high level is 1.8V)	
4	RTC_EINT	I	RTC external interrupt	
5	USB_DM	I/O	USB D- line. Leave unconnected if not used.	
6	USB_DP	I/O	USB D+ line. Leave unconnected if not used.	
7	VUSB	I	USB voltage supply. Connect this pin to 2.92 ~ 3.22V to enable USB interface. Leave unconnected if not used.	1
8	EN	I	Enable the module, high active. Internal 1M ohm pull-up resistor to 1.8V. Setting this pin to low also resets the real-time clock which means that the receiver cannot perform hot start immediately after Enable. Leave unconnected if not used.	

9	VCC_RF	O	Output voltage for active antenna	
10	GND	P	Ground	
11	RF_IN	I	GNSS RF signal input. The overall gain of the active antenna must be between 8dB ~ 25dB	
12	GND	P	Ground	
13	GND	P	Ground	
14	LNA_EN	O	Output pin to control the external LNA, high active. Internal pull down.	
15	GPIO26	I/O	General purpose I/O	
16	RSV		Reserved pin. Leave unconnected.	
17	RSV		Reserved pin. Leave unconnected.	
18	TX2	O	Serial output 2. Leave unconnected if not used.	
19	RX2	I	Serial input 2. Leave unconnected if not used.	
20	TX	O	Serial output	
21	RX	I	Serial input	
22	V_BCKP	P	Backup battery input. It is recommended to connect a backup supply voltage to V_BCKP in order to enable warm and hot start features. Moreover, V_BCKP is a must of the system running. If no backup power is available, connect V_BCKP to the main power supply (VCC).	2
23	VCC	P	DC supply input. Must be clean and stable.	
24	GND	P	Ground	

Note 1: USB selective suspend function is not supported.

Note 2: In order to get the advantage of hybrid ephemeris prediction, this pin must be always powered during the period of effective ephemeris prediction.

Note 3: If an abnormal input voltage as shown in the figure below is input, even if the correct voltage is input again later, the module may not work until V_BCKP pin is re-powered.

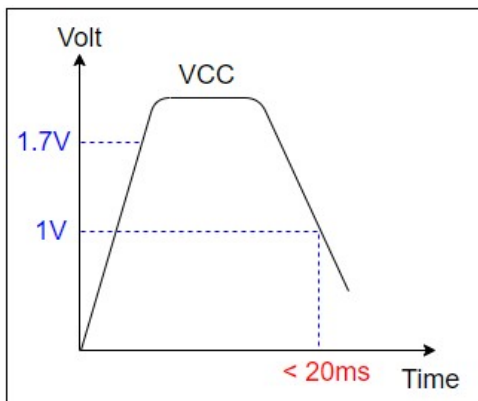

7 DC & Temperature characteristics

7.1 Absolute maximum ratings

Parameter	Symbol	Ratings	Units
DC Supply Input Voltage	VCCabs	5.5	V
Input Backup Battery Voltage	V_BCKPabs	5.5	V
Operating Temperature Range	Topr_abs	-40 ~ 85	°C
Storage Temperature Range	Tstg_abs	-40 ~ 85	°C

7.2 DC Electrical characteristics

Parameter	Symbol	Conditions	Min.	Typ.	Max.	Units
DC Supply Input Voltage	VCC		3.1	3.3	4.5	V
Input Backup Battery Voltage	V_BCKP		2.0		4.5	V
VCC_RF Output Voltage	VCC_RF			VCC		V
Supply Current	MC-1612-V2b	I _{ss}	VCC = 3.3V, w/o active antenna, Peak Acquisition Tracking		140 ⁽¹⁾	mA
				37		mA
	MC-1612-V3b		VCC = 3.3V, w/o active antenna, Peak Acquisition Tracking		110 ⁽¹⁾	mA
		I _{shdn}	VCC=3.3V, EN=0V	22		uA
Backup Battery Current	I _{bat}	VIN = 0V		64		uA
VCC_RF Output Current	I _{out}	VIN = 3.3V			30	mA
High Level Input Voltage	V _{IH}	For TX, RX	2.2		3.6	V
Low Level Input Voltage	V _{IL}		-0.3		0.8	V
High Level Output Voltage	V _{OH}		2.18		3.3	V
Low Level Output Voltage	V _{OL}				0.4	V
High Level Input Voltage	V _{IH}	For TIMEPULSE, RTC_EINT, EN, LNA_EN, GPIO26, TX2, RX2	1.21		1.98	V
Low Level Input Voltage	V _{IL}		-0.3		0.6	V
High Level Output Voltage	V _{OH}		1.29		1.98	V
Low Level Output Voltage	V _{OL}				0.45	V

Note 1: This happens when downloading AGPS data to the module.

Note 2: Measured when position fix (1Hz) is available, input voltage is 3.3V and the function of self-generated ephemeris

prediction is inactive. If USB interface is enabled, it will increase about 8mA.

7.3 Temperature characteristics

Parameter	Symbol	Min.	Typ.	Max.	Units
Operating Temperature	Topr	-40	-	85	°C
Storage Temperature	Tstg	-40	25	85	°C

8 Mechanical specification

8.1 Outline dimensions

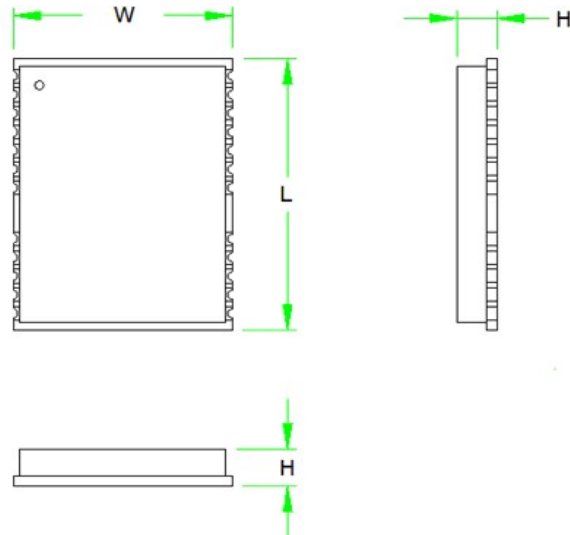

Symbol	Min. (mm)	Typ. (mm)	Max. (mm)
W	12.1	12.2	12.3
L	15.7	16.0	16.4
H	2.2	2.4	2.6

8.2 Recommended land pattern dimensions

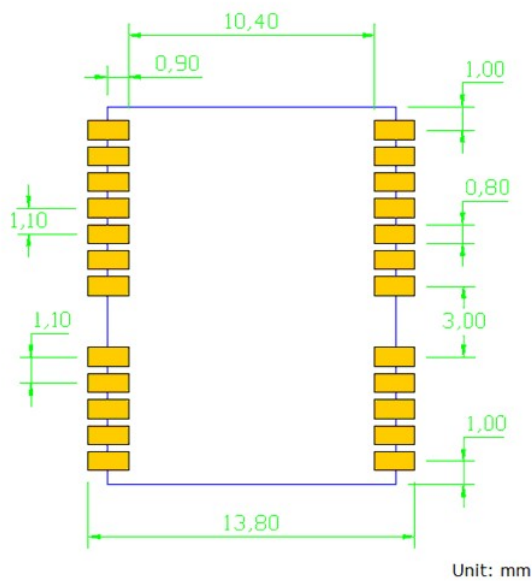

Note: The recommended land pattern dimensions are shown for reference only, as actual pad layouts may vary depending on application.

9 Reel Packing information

9.1 ESD precaution

GNSS modules are electrostatic sensitive devices. Handling the modules without proper ESD protection may result in severe damage to them. ESD protection must be implemented throughout the processing, handling and even when the modules are being returned for repair.

9.2 Packaging

The modules are sealed in a moisture barrier ESD bag with the appropriate units of desiccant and a humidity indicator card. It should not be opened until the modules are ready to be soldered onto the application.

9.2.1 Packaging

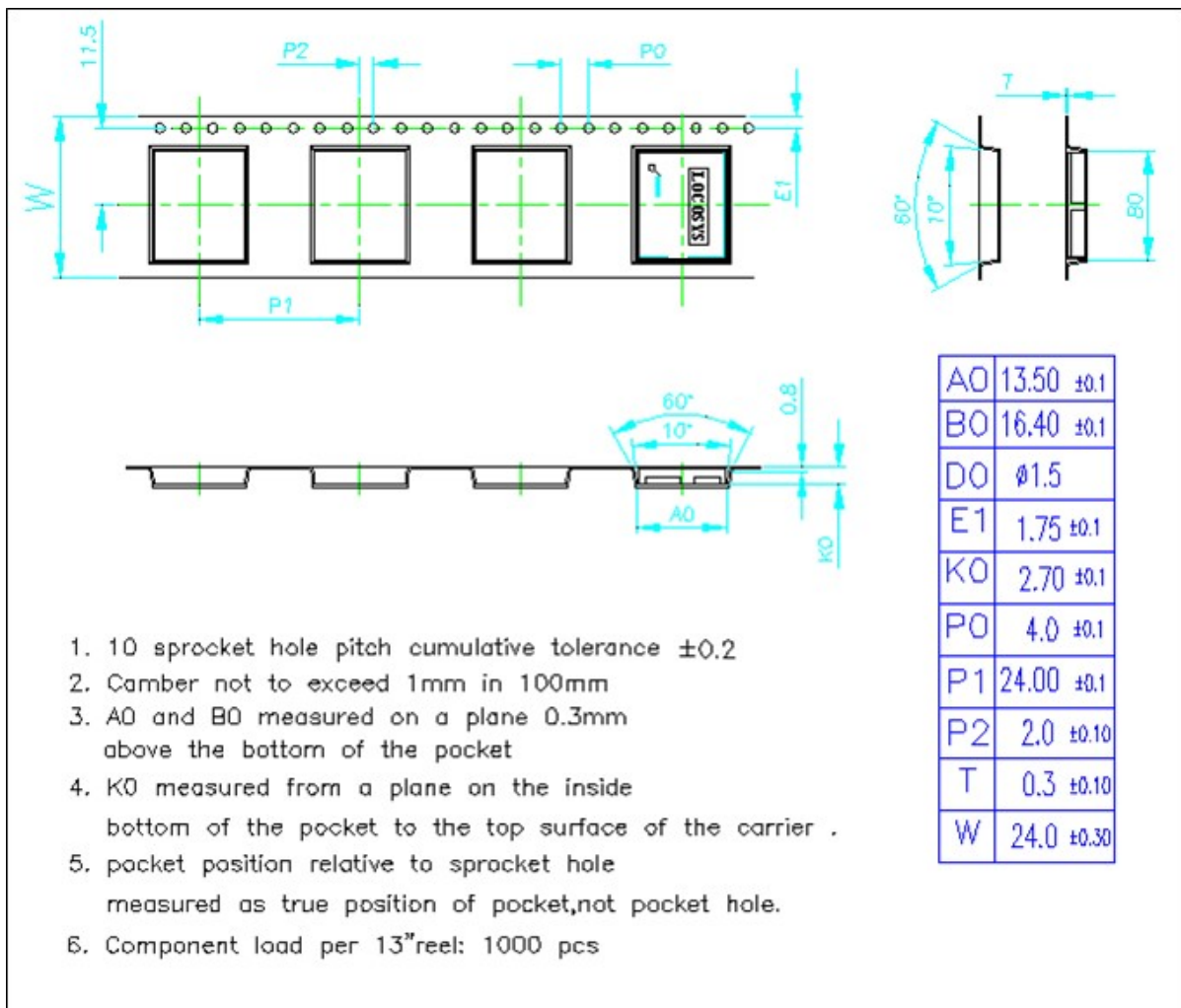

9.2.2 Box packaging

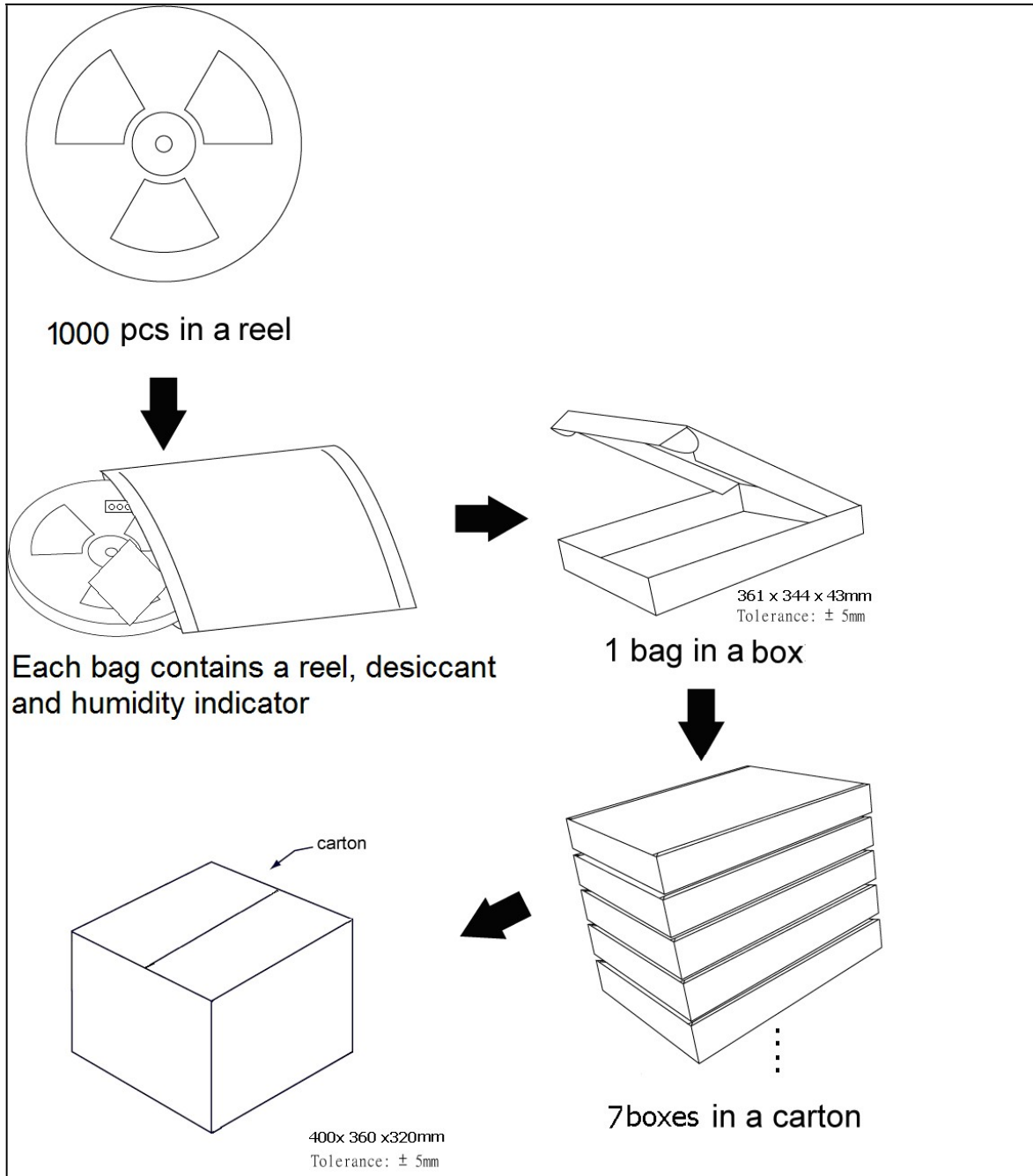

9.3 Moisture sensitivity level

The moisture sensitivity level of the module is 3. After the sealed bag is opened, modules should be mounted within 168 hours at factory conditions of $\leq 30^{\circ}\text{C}$ and 60% RH or stored at $\leq 20\%$ RH.

The modules require baking before mounting if above conditions are not met. If baking is required, the modules without the tape and reel may be baked for:

- a. 192 hours at $40^{\circ}\text{C} + 5^{\circ}\text{C} / -0^{\circ}\text{C}$ and $< 5\%$ RH
- b. 24 hours at $125^{\circ}\text{C} + 5^{\circ}\text{C} / -0^{\circ}\text{C}$

9.4 Reflow soldering

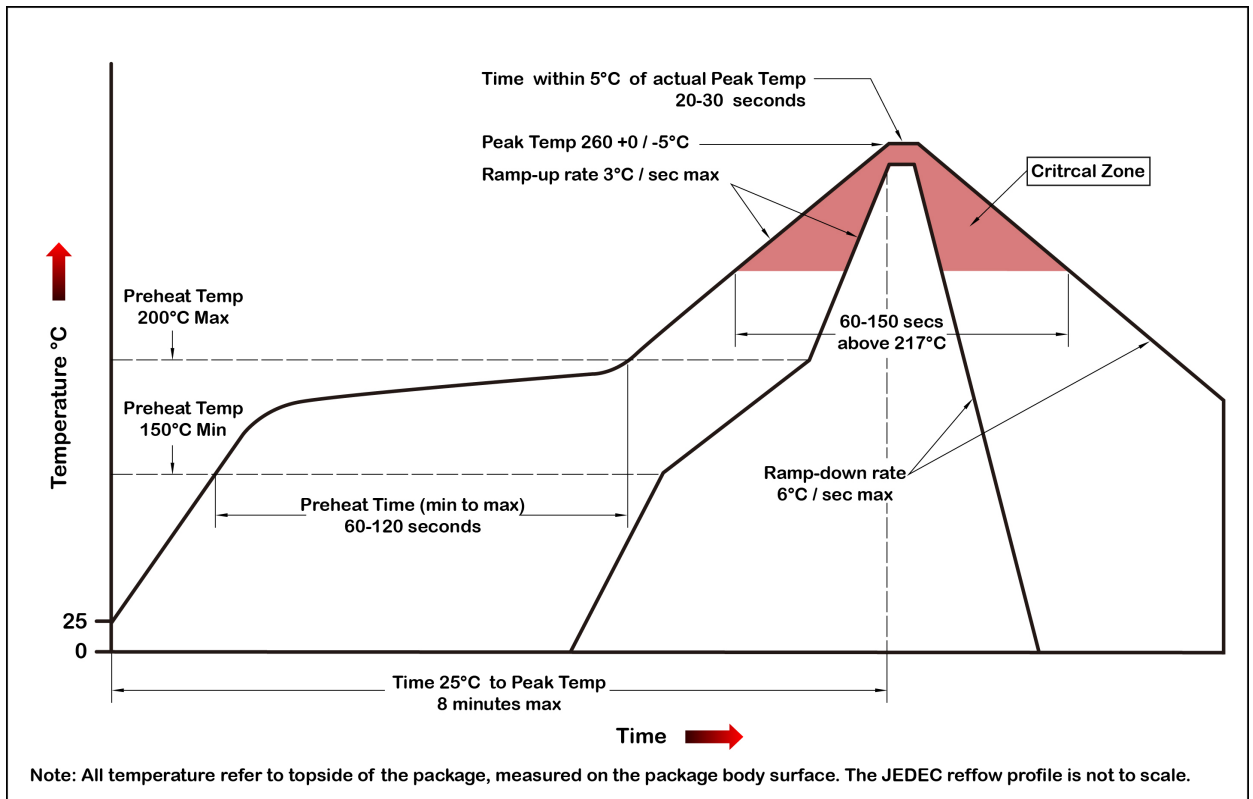

Note the module mounted to the top side (first reflow side) may fall off during reflow soldering of the bottom side.

10 Product marking and ordering information

10.1 Product marking

The marking of the module is engraved on the metal shielding that has product information, such as LOCOSYS logo, product name and manufacturing date.

10.2 Ordering information

Product name	Description	Remark
MC-1612-V2b	Dual-frequency multi-constellation GNSS positioning module	GPS/QZSS: L1 C/A, L5C GLONASS: L1OF GALILEO: E1, E5a BEIDOU: B1I, B2a
MC-1612-V3b	Dual-frequency multi-constellation GNSS positioning module	GPS/QZSS: L1 C/A GLONASS: L1OF GALILEO: E1 BEIDOU: B1I IRNSS (NAVIC): L5

Document change list

Revision 0.1

- Draft release on August 12, 2020.

Revision 0.2 (August 24, 2020)

- Added the compliant description of AIS 140 in section 1.
- Added the Note in the Fig 3-2.

Revision 0.3 (September 24, 2020)

- Added the proprietary command sets in section 5.2.

Revision 0.4 (November 23, 2020)

- Revised the signal ID of GALILEO in table 5.1-9.
- Added the note about USB selective suspend function in table 6-1.
- Added the description of EN pin in table 6-1.
- Changed the peak current to 110mA in section 7.2.
- Changed the acquisition current to 37mA in section 7.2.
- Changed the tracking current to 56mA in section 7.2.
- Added the supply current when EN pin is 0V in section 7.2.
- Added the note of the increased current of USB interface in section 7.2.
- Added IO voltage for TIMEPULSE, RTC_EINT, EN, LNA_EN, GPIO26, TX2, RX2 in section 7.2.

Revision 0.5 (June 1, 2021)

- Added support of QZSS SLAS.
- Added “Support Linux and Android OS driver” in section 2.
- Added “Protocol support binary output” in section 2.
- Added application of femtocell 、 small-cell timing device in section 3.
- Changed the max. velocity from 515 m/s to 500 m/s in section 4.
- Changed autonomous position accuracy from 1m CEP to 1.5m CEP.
- Added autonomous accuracy of MC-1612-V3b in section 4.
- Added GST to default output message in section 4.
- Added note about module protocol support binary output in section 4.
- Added the description of GST in section 5.1.
- Revised the proprietary command sets in section 5.2.
- Added section 5.3.
- Changed the overall gain of the active antenna to be 8dB ~ 25dB in section 6.
- Changed VCC_RF Output Voltage from 3V to VCC in section 7.2.
- Added the current of MC-1612-V3b in section 7.2.
- Revised the reflow soldering profile in section 9.4.

Revision 0.6 (June 22, 2021)

- Changed MC-1612-V2b's peak current from 110mA to 140mA in section 7.2.
- Changed MC-1612-V2b's tracking current from 56mA to 58mA in section 7.2.
- Changed the backup battery current from 44uA to 64uA in section 7.2.

Revision 1.0 (July 6, 2021)

- Official release.

Revision 1.1 (September 15, 2021)

- Added the note for VCC pin in section 6.